



Cambridge O Level

CANDIDATE
NAME

CENTRE
NUMBER

--	--	--	--	--

CANDIDATE
NUMBER

--	--	--	--



DESIGN & TECHNOLOGY

6043/32

Paper 3 Resistant Materials

October/November 2021

1 hour

You must answer on the question paper.

No additional materials are needed.

INSTRUCTIONS

- Section A: answer **all** questions.
- Section B: answer **one** question.
- Use a black or dark blue pen. You may use an HB pencil for any diagrams or graphs.
- Write your name, centre number and candidate number in the boxes at the top of the page.
- Answer in the space provided.
- Do **not** use an erasable pen or correction fluid.
- Do **not** write on any bar codes.
- You may use a calculator.

INFORMATION

- The total mark for this paper is 50.
- The number of marks for each question or part question is shown in brackets [].
- All dimensions are in millimetres.

This document has **20** pages. Any blank pages are indicated.

Section A

Answer **all** questions in this section.

- 1 Safety precautions need to be taken when carrying out different processes in a workshop. Complete Table 1.1 by stating **one** safety precaution that would need to be taken for each process.

Table 1.1

Process	Safety precaution taken
Using a pillar drill to drill sheet metal	
Using a disc sander to sand a hardwood block	

[2]

- 2 **Circle** from the list of materials below **one** metal that can be hardened.

lead

zinc

high carbon steel

cast iron

[1]

- 3 Fig. 3.1 shows two pieces of hardwood that are to be joined by means of a KD (Knock-Down) fitting.

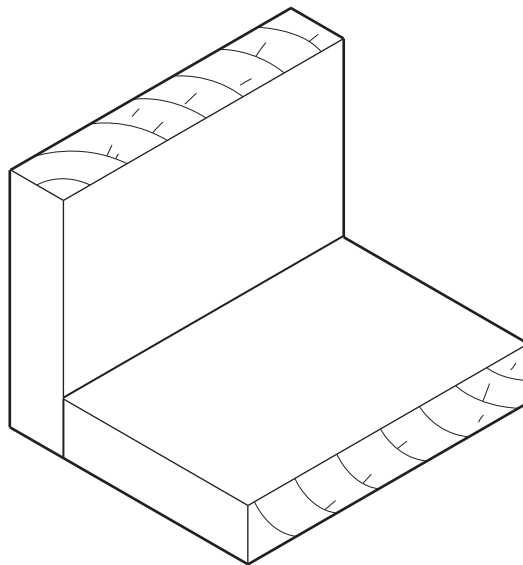

Fig. 3.1

Add sketches and notes to Fig. 3.1 to show how a suitable KD (Knock-Down) fitting could be used to join the hardwood together. [3]

4 Fig. 4.1 shows two tools, **A** and **B**, that are used to remove nails from wood.

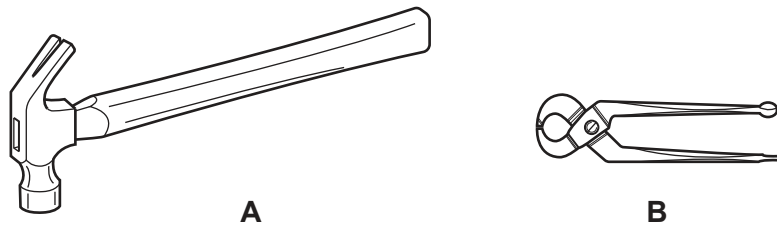

Fig. 4.1

(a) Name each tool:

A

B

[2]

(b) Fig. 4.2 shows tool **A** removing a nail from wood.

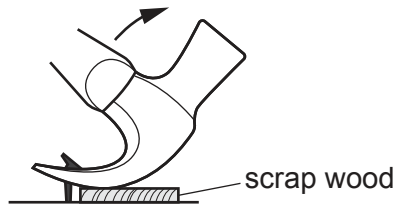

Fig. 4.2

State the purpose of the scrap wood shown in Fig. 4.2.

..... [1]

5 Fig. 5.1 shows an item of equipment used to hold components when drilling holes.

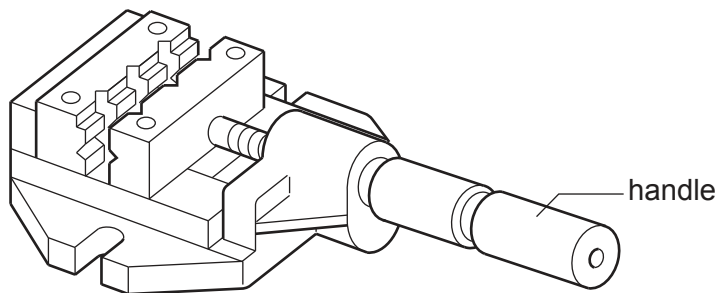

Fig. 5.1

(a) Give the correct name for the item of equipment shown in Fig. 5.1.

..... [1]

(b) State the name of a centre lathe process that could have been carried out to the handle to improve grip.

..... [1]

6 Fig. 6.1 shows a hardwood bracket. The bracket has been fabricated using hardwood.

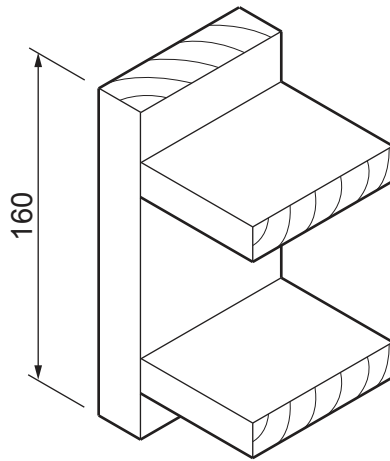

Fig. 6.1

(a) State what is meant by the term 'fabricated'.

..... [1]

(b) The bracket could be made from aluminium.
State a manufacturing process that could be used to produce the bracket from one piece of aluminium.

..... [1]

7 Fig. 7.1 shows an incomplete design for a bending jig used when bending acrylic sheet.

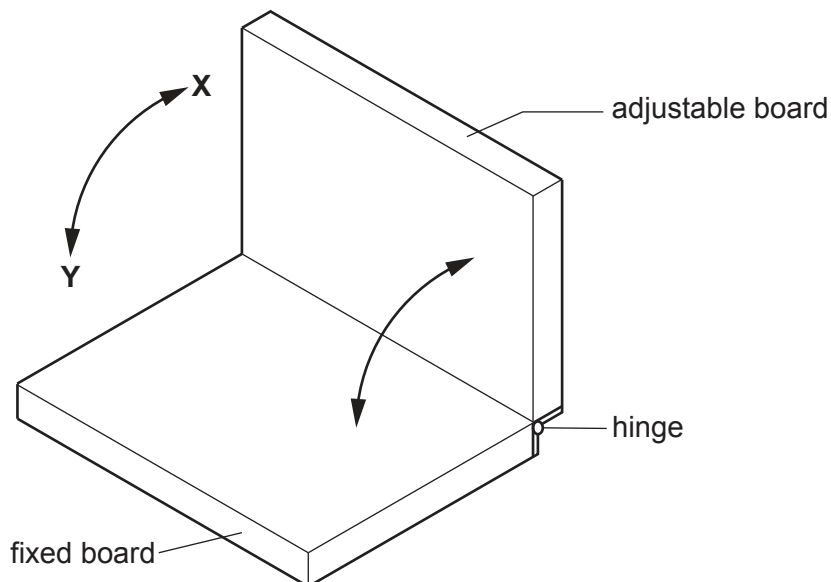

Fig. 7.1

Add to Fig. 7.1 to show how the adjustable board could be held securely in any position between X and Y so that acrylic sheet could be bent to the required shape. [3]

8 Fig. 8.1 shows a leaflet holder made from 3 mm thick acrylic.

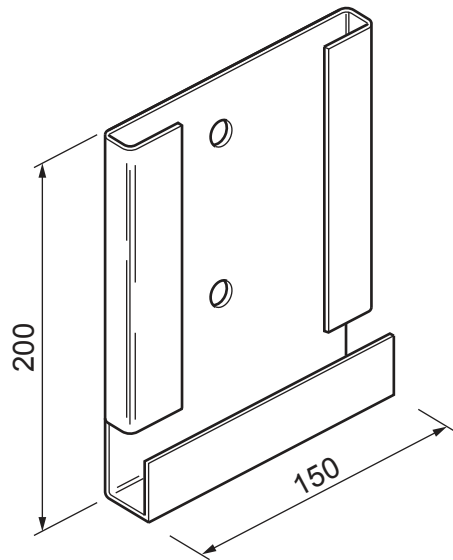

Fig. 8.1

Complete Table 8.1 by describing what each of the tools or items of equipment could be used for when making the leaflet holder.

Table 8.1

Tool/item of equipment	What they are used for
Chinagraph pencil	
Scroll saw	
Hand file	
Buffing machine	

[4]

9 Complete the statement below by adding the correct term from the list.

- moisture temperature weight light**

Shape Memory Alloy (SMA) is a smart material that reacts to [1]

- 10 Fig. 10.1 shows the underside of a table top.
The table top is made by gluing together three hardwood boards.

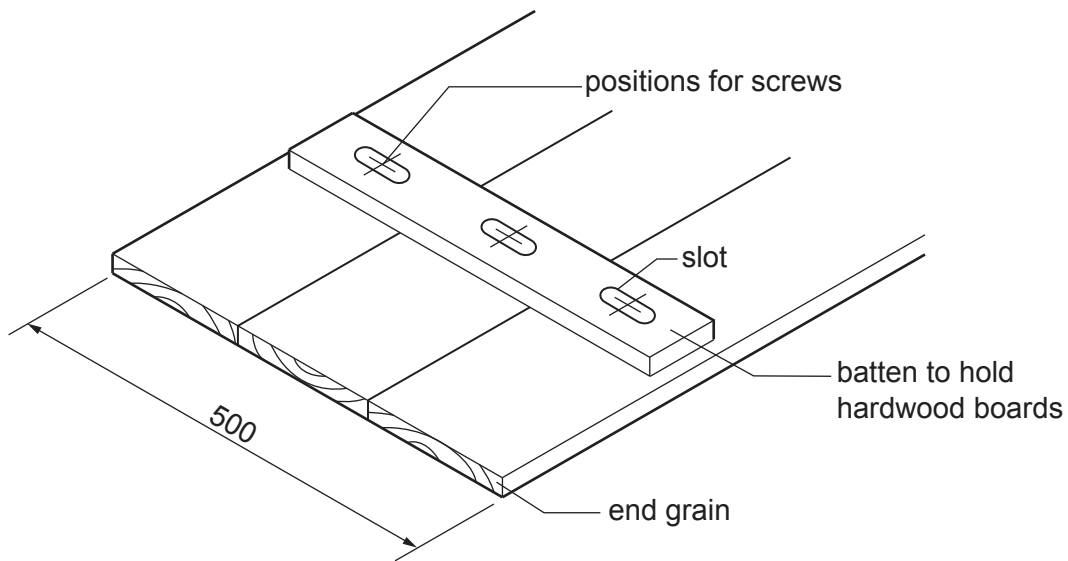

Fig. 10.1

- (a) Give **one** reason why the table top is made by gluing together three hardwood boards rather than one board.

..... [1]

- (b) Explain why the boards have been glued together with the end grains arranged as shown in Fig. 10.1.

.....

 [2]

- (c) Fig. 10.1 shows a batten that is used to hold the three hardwood boards.
The batten will be screwed to the underside of the table top.
Give **one** reason why the screw holes are slotted.

..... [1]

Section B

Answer **one** question from this section.

- 11 Fig. 11.1 shows an incomplete design for a step stool made from oak.

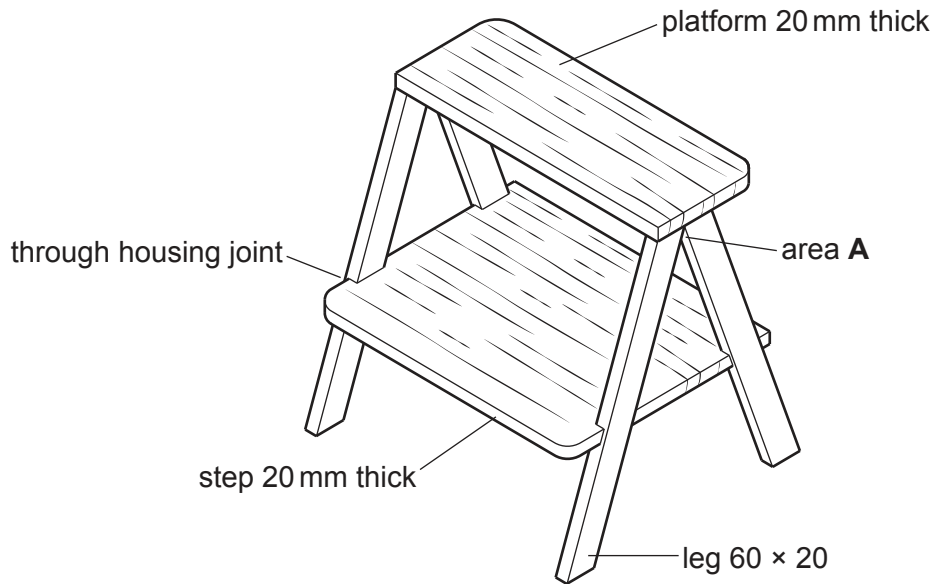

Fig. 11.1

- (a) Give **two** properties of oak that make it suitable for the step stool.

1.....

2.....

[2]

- (b) The legs will be cut from one length of 60 × 20 oak.
Use sketches and notes to show how a sliding bevel could be used when marking out **one** leg.

[2]

(c) Fig. 11.2 shows part of one leg.

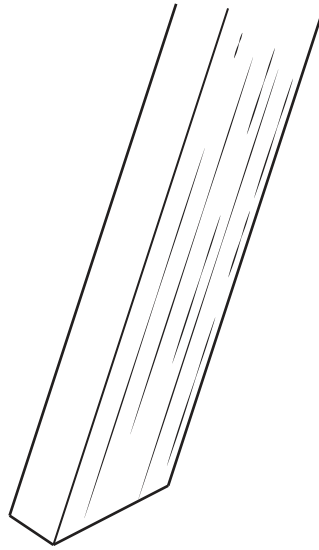

Fig. 11.2

- (i) Draw on Fig. 11.2 to show a through housing joint that could be used to join the step to the leg. [3]
- (ii) Fig. 11.3 shows a portable power tool that could be used to cut the through housing joints.

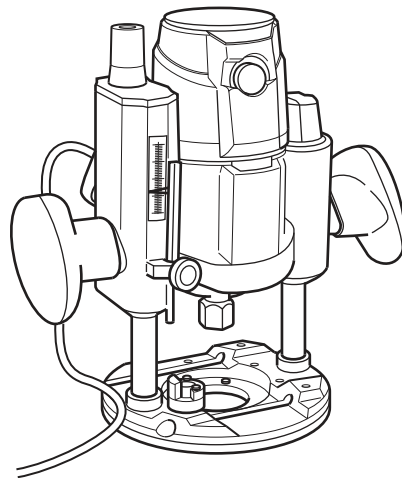

Fig. 11.3

Name the portable power tool. [1]

- (iii) State **one** safety precaution, other than wearing PPE (Personal Protection Equipment), that must be taken when using portable power tools.

..... [1]

- (d) The platform shown in Fig. 11.1 will be joined to the tops of the legs using dowels. Fig. 11.4 shows the tops of two legs.

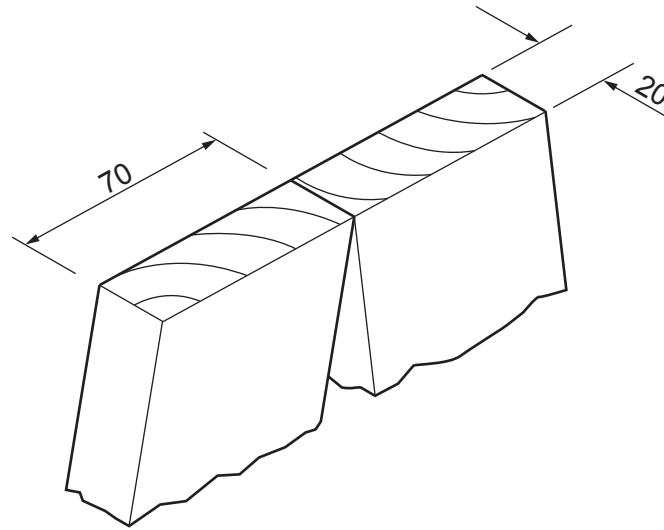

Fig. 11.4

Draw on Fig. 11.4 to show:

- the diameter of dowel pegs used
- the number of dowel pegs required
- the spacing between the dowel pegs.

[3]

- (e) Area **A** shown in Fig. 11.1 is weak and needs to be strengthened. Use sketches and notes to show how additional materials and constructions could be used to make area **A** stronger and more rigid.

[3]

(f) The step stool will be given an oiled finish rather than a painted finish.

(i) Give **two** advantages of an oiled finish rather than a painted finish for the step stool.

1

2 [2]

(ii) The step will be glasspapered, ready to take the oiled finish, **before** it is glued to the legs.

Give **two** benefits of glasspapering the step before it is glued to the legs.

1

2 [2]

(g) A hand-hold will be joined to the step stool to provide support for the user. Add sketches and notes to Fig. 11.5 to show a design for a hand-hold that would provide support at a height of 1 metre above the platform.

Include the following details:

- the method of joining the hand-hold securely to the step stool
- **two** important sizes
- how the hand-hold is made comfortable to grip.

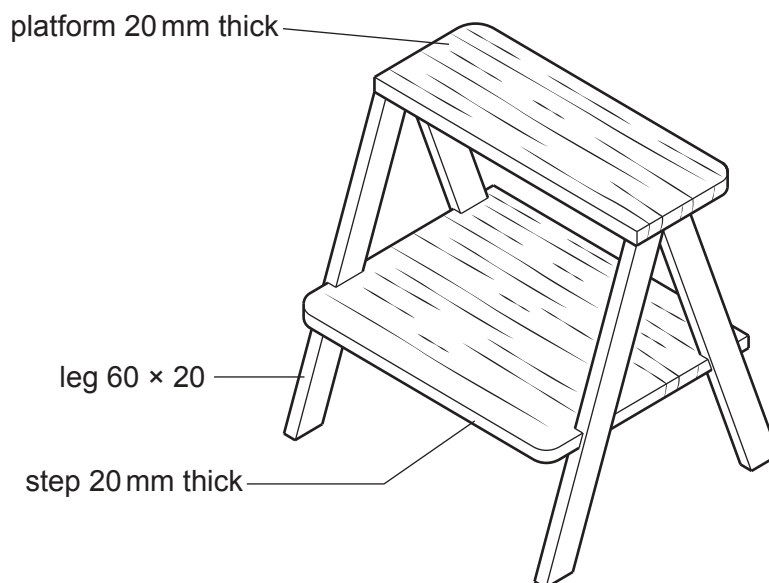

Fig. 11.5

[6]

12 Fig. 12.1 shows parts of an incomplete model car.

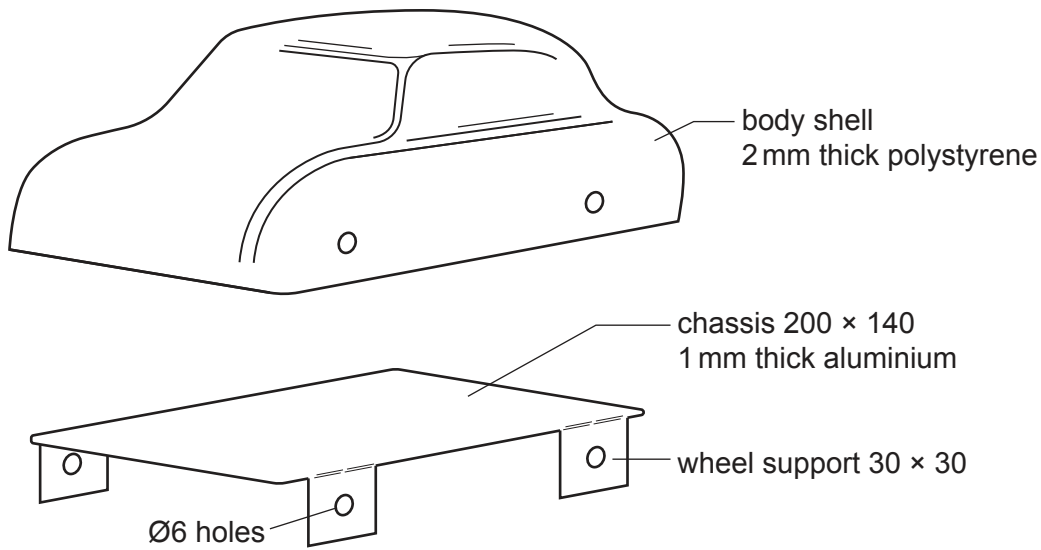

Fig. 12.1

(a) Give **two** advantages of using CAD rather than traditional drawing methods to design the body shell of the model car.

- 1
- 2 [2]

(b) Give **two** benefits of using aluminium for the chassis of the model car.

- 1
- 2 [2]

(c) The body shell will be produced by vacuum forming.

(i) State **two** features of the mould used to produce a quality body shell.

- 1
- 2 [2]

(ii) Give **two** reasons why it is important to heat the polystyrene to the correct temperature when vacuum forming the body shell.

- 1
- 2 [2]

(iii) A flow chart showing the stages of vacuum forming the body shell of the model car is shown below.

Complete the flow chart by adding the missing stages needed from the list below.

- Turn off vacuum
- Is shape fully formed?
- Lower mould
- Turn on vacuum
- Remove vacuum formed body shell
- Is plastic soft enough?
- Raise mould

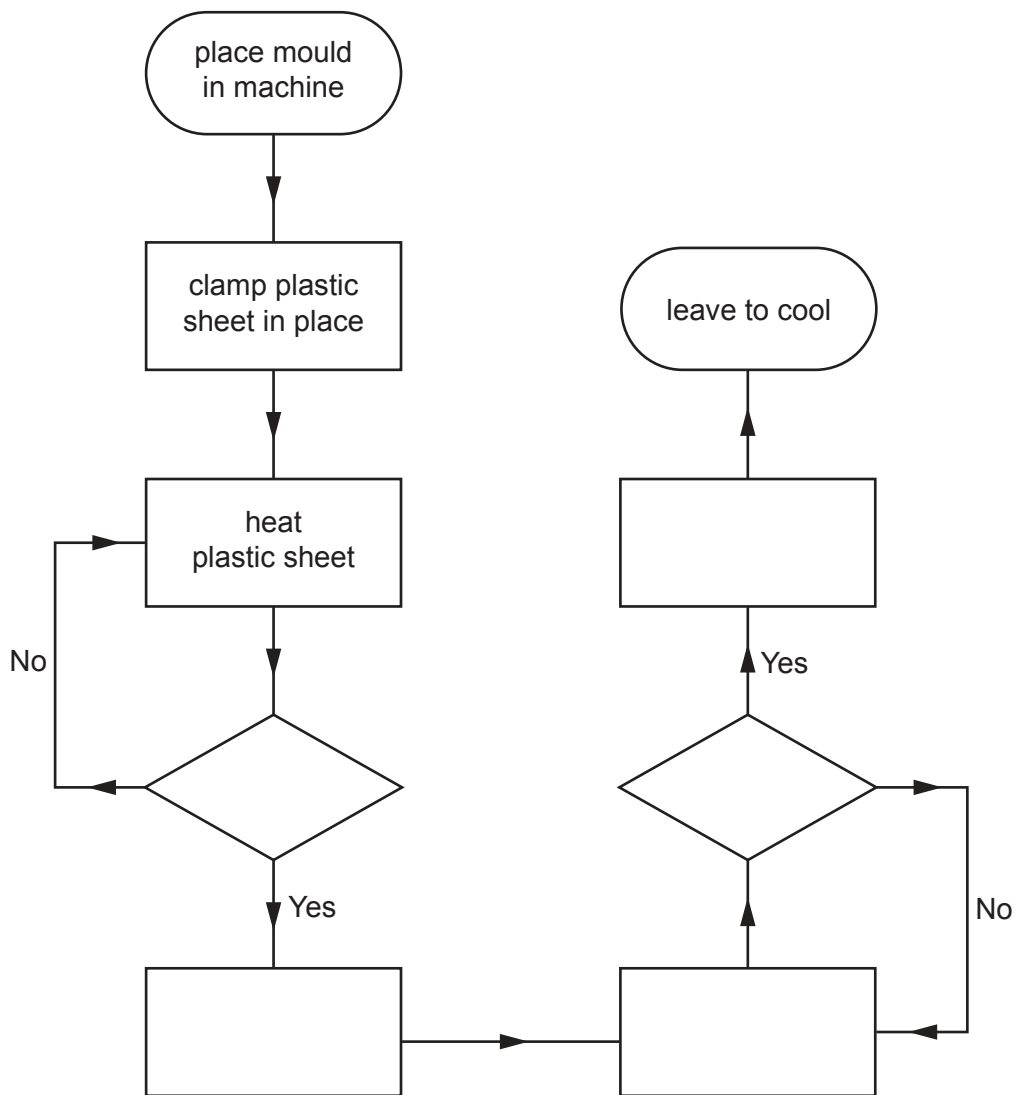
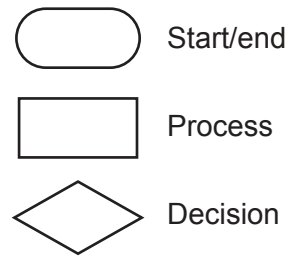

[5]

(d) The chassis will be cut from a sheet of 1 mm thick aluminium shown below.

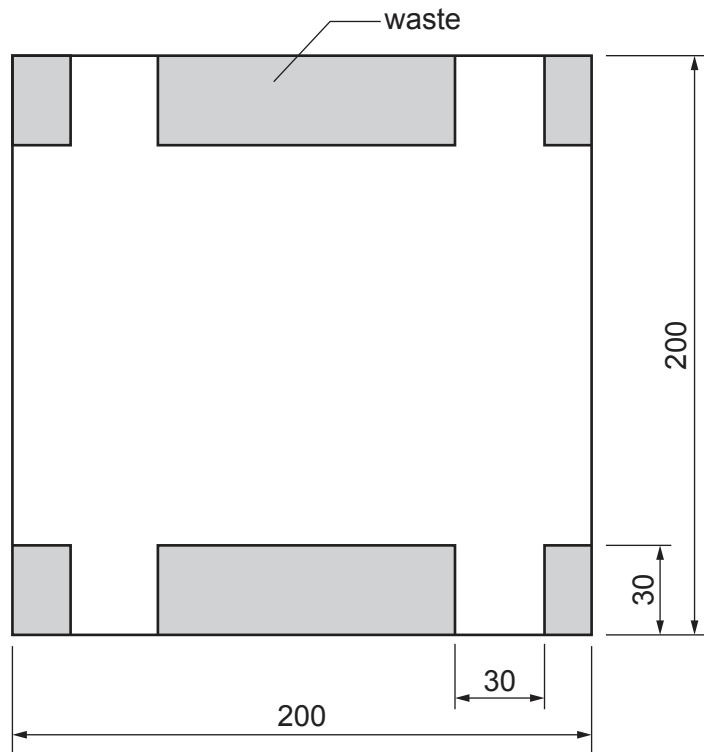

(i) Name **two** hand tools that could be used to cut out the development (net) of the chassis.

1

2

[2]

(ii) Describe how the cut edges could be made safe to handle.

.....

..... [2]

(iii) Use sketches and notes to show how the wheel supports could be bent to shape.
Name the tools and equipment used.

[3]

(e) Fig. 12.2 shows one of the wheels that will be fitted to the model car.

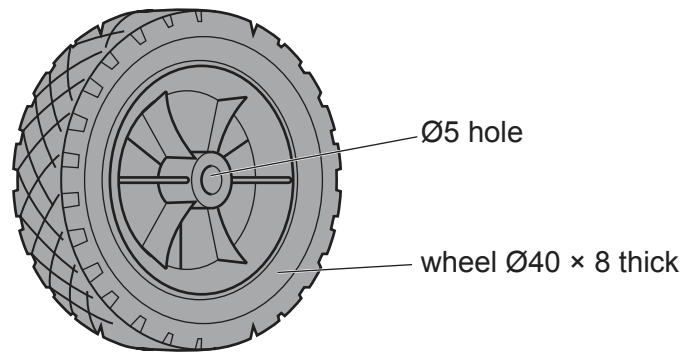

Fig. 12.2

(i) Name the process used to manufacture the plastic wheel.

..... [1]

(ii) The body shell fits over the chassis and is held securely when axles are inserted and the wheels are attached.

Use sketches and notes to show how wheels could be fitted to the model car and allowed to rotate freely.

[4]

13 Fig. 13.1 shows an incomplete design for a jewellery stand made from mahogany and brass.

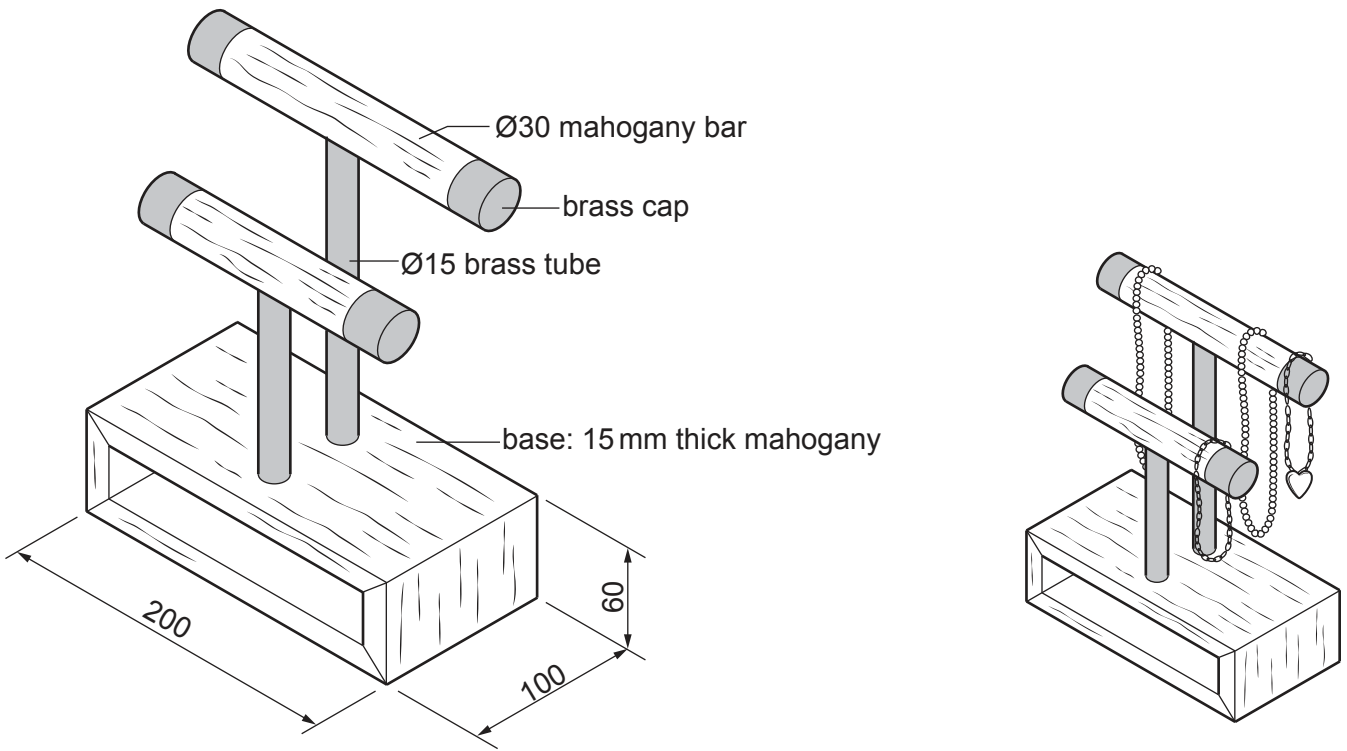

Fig. 13.1

- (a) The Ø30 mahogany bars will be produced on a woodturning lathe by means of between-centres turning.
 Fig. 13.2 shows the length of mahogany marked out and prepared, ready to be set up on a woodturning lathe.

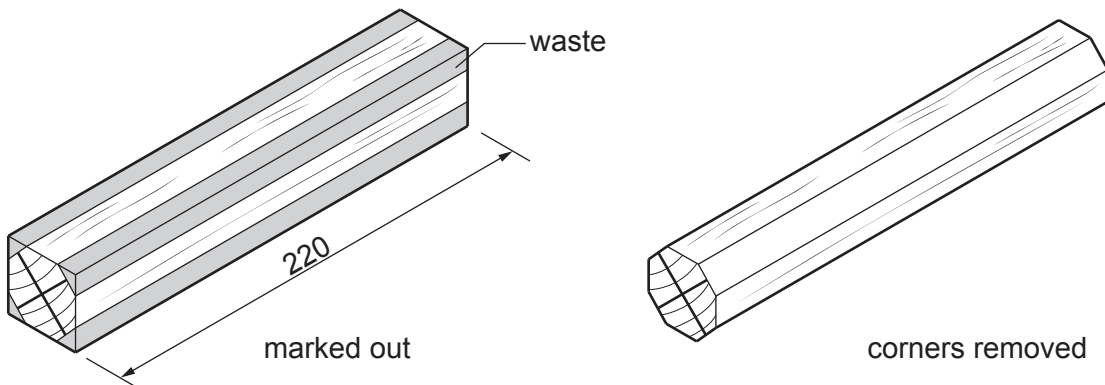

Fig. 13.2

- (i) Give **one** reason why the corners of the mahogany have been removed.
 [1]
- (ii) When setting up the mahogany on a woodturning lathe state **one** check that would be carried out before switching on the machine.

 [1]

(iii) Name **one** tool that could be used to check that the mahogany has been turned to the correct diameter.

..... [1]

(iv) Name **one** lathe tool that could be used to remove the waste to make the length of mahogany round.

..... [1]

(b) Fig. 13.3 shows an engineers vice that will be used to hold each of the Ø15 brass tubes while they are sawn to the required length.

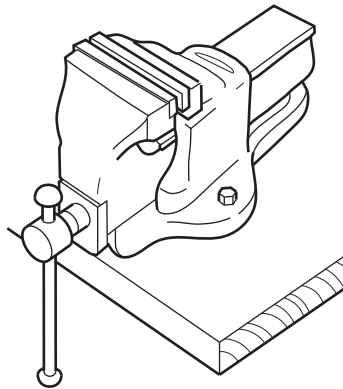

Fig. 13.3

Describe **one** precaution that could be taken to prevent the brass tubes from being damaged when held in the engineers vice.

.....
..... [2]

(c) Fig. 13.4 shows a brass cap that is fixed over the end of the mahogany bars.

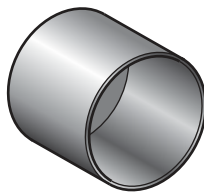

Fig. 13.4

(i) State the purpose of the brass caps.

..... [1]

(ii) The brass caps are pre-manufactured components that have been purchased. Give **two** advantages of using pre-manufactured components rather than making the components in a school workshop.

- 1
- 2

[2]

- (d) The sides of the base, made from mahogany, will be joined by means of mitre joints. Fig. 13.5 shows a mitre joint marked out on the end of one side.

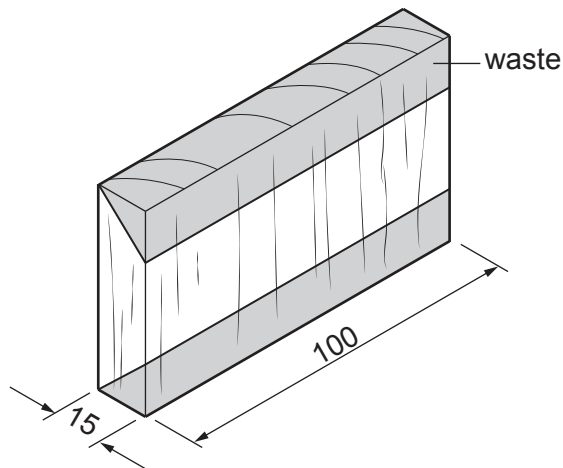

Fig. 13.5

- (i) Name **two** tools that could be used to mark out the mitre joint.

1

2

[2]

- (ii) Use sketches and notes to show how the waste could be removed to produce the mitre joint. Name the tools and equipment used.

[4]

(e) Fig. 13.6 shows the base of the jewellery stand.

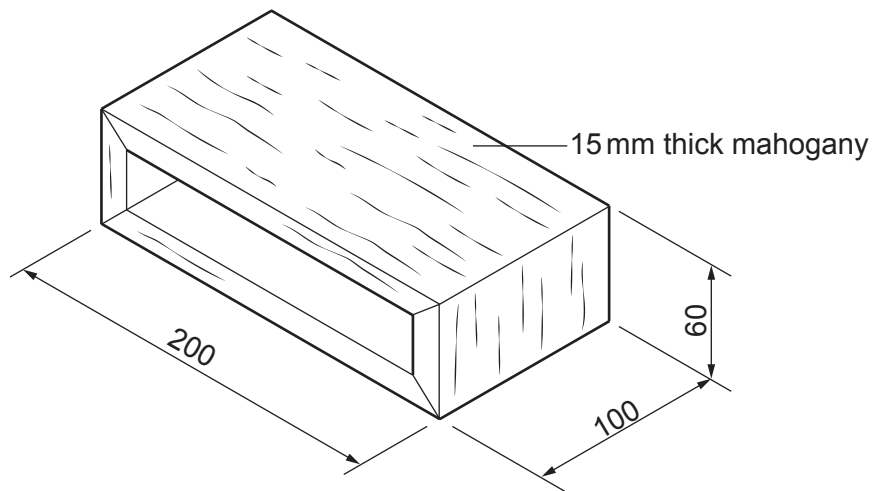

Fig. 13.6

Use sketches and notes to show a design for a drawer that would fit into the base. Include the constructions and sizes of materials used.

[6]

(f) Fig. 13.7 shows 1 mm thick brass sheet from which a handle for the drawer will be produced.

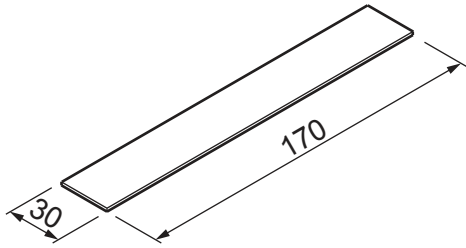

Fig. 13.7

Use sketches and notes to show a design for a handle that will be attached to the front of the drawer. The design can use **all** or **part** of the brass sheet. Include details of any cutting and shaping processes used to produce the handle.

[4]

BLANK PAGE

Permission to reproduce items where third-party owned material protected by copyright is included has been sought and cleared where possible. Every reasonable effort has been made by the publisher (UCLES) to trace copyright holders, but if any items requiring clearance have unwittingly been included, the publisher will be pleased to make amends at the earliest possible opportunity.

To avoid the issue of disclosure of answer-related information to candidates, all copyright acknowledgements are reproduced online in the Cambridge Assessment International Education Copyright Acknowledgements Booklet. This is produced for each series of examinations and is freely available to download at www.cambridgeinternational.org after the live examination series.

Cambridge Assessment International Education is part of the Cambridge Assessment Group. Cambridge Assessment is the brand name of the University of Cambridge Local Examinations Syndicate (UCLES), which itself is a department of the University of Cambridge.